

















MOFFAT E32MS on the A25CW

Full Size Electric Convection Oven on a Stainless Steel Stand

-  Robust stainless steel exterior for long life
-  Porcelain inner for easy cleaning and durability
-  Stainless steel door with large viewing window for extra visibility
-  Door is field reversible for line end positioning
-  Stay cool heavy duty stainless steel door handle
-  4 full sheet pan capacity (6 with optional cookie kit)
-  Hot reversing air fan system for more even bake results
-  Easy to use mechanical controls
-  60 minute timer for baking
-  3 hour roasting timer with cook n hold system
-  Internal lighting
-  Water injected steam (hook-up optional)
-  Quiet in operation – can be used front of house
-  Utility required only 40 amp breaker (6kW)
-  Stand constructed in stainless steel
-  Casters standard
-  Rack supports



E32MS on A25CW stand



Order Toll Free 1800 551 8795

E32MS on the A25CW

Unit shall be a Moffat electrically heated Turbofan convection oven with hot air reversing fan system ETL listed (UL Std 197) and NSF listed (NSF-4). The oven shall have a one piece vitreous porcelain enamel oven liner, stainless steel top and sides with single stainless steel door and full size viewing window. Door shall be field reversible. Oven liner shall be insulated on all sides and have capacity for 4 full size sheet pans or 6 with cookie kit option. The oven temperature shall be controlled by a mechanical thermostat and shall have a bake timer, roast timer, cook 'n hold system and feature water injection for optional connection.

The stand shall be constructed from stainless steel tube with casters, 2 swivel and 2 brake. Stand shall be fitted with 6 sets of tray runners suitable for up to 12 half size sheet pans or 6 full size sheet pans. Oven shall also be able to be double stacked with stacking kit, bench mounted on 4" legs, or mounted on Moffat's E89 Proofer and Holding Cabinet. 8kW optional.

MOFFAT® E32MS on the A25CW

Full Size Electric Convection Oven on a Stainless Steel Stand

CONSTRUCTION (E32)

Stainless steel top and sides
Enamel oven interior
Field reversible door
Toughened twin pane door glass
Strong and stylish door handle
4 pan capacity (4 wire oven racks included)
Fully insulated
Stainless steel control panel with overlay
Fully enclosed motor

CONSTRUCTION (A25)

Stainless steel frame and rack supports
Strong robust and functional
Casters
Supplied knocked down for assembly on site

CONTROLS

On/off switch
Mechanical thermostat,
variable between 150°F to 600°F
1 hour bake timer with buzzer
3 hour roast timer
Cook n hold factory preset at 158°F
(range 140°F to 194°F)
Water injection steam (momentary switch)
Hot reversing fan system
2 oven lights

CLEANING AND SERVICING

Easy clean stainless steel and enamel surfaces
Fully removable racks and baffle
Access to all controls from front panel
Full access side service panel
Removable door seals

OPTIONS

Cookie kit
E89 Proofer and Holding Cabinet
Double stacking kit
Full range of 18" x 26" pans
Chicken racks

SPECIFICATIONS

Electrical requirements
208V, 60Hz, 6kW, 28.8A
220-240V, 60Hz, 6.66kW, 27.8A
1 phase, 2 wire + GND (cord & connection required)

Water
3/4" thread
80psi max inlet pressure
20psi min inlet pressure

External Dimensions
Width 28" (710mm)
Height 62 1/4" (1581mm on stand)
26 3/8" (670mm on feet)
Depth 32" (810mm)

Internal Dimensions (E32)
Width 18" (460mm)
Height 21" (533mm)
Depth 26" (660mm)

Oven Rack Dimensions
Width 18" (460mm)
Depth 26" (660mm)
Between racks 5" (125mm)
3" (75mm) with cookie kit

Nett Weight (total)
222lbs (101kg)

Packing Data (E32)
181lbs (82kg)
19.6ft³ (0.56m³)
Width 29 1/2" (750mm)
Height 31" (785mm)
Depth 37" (945mm)

Packing Data (A25)
42lbs (19kg)
3.2ft³ (0.09m³)
Width 28 3/8" (720mm)
Height 35 1/2" (900mm)
Depth 5 3/4" (145mm)

Clearances
Left side 3" (75mm)
Right side 3" (75mm)*
Rear 3" (75mm)
Top 8" (200mm)

*Fixed installations require at least 500mm(20") clearance at RHS for serviceability.

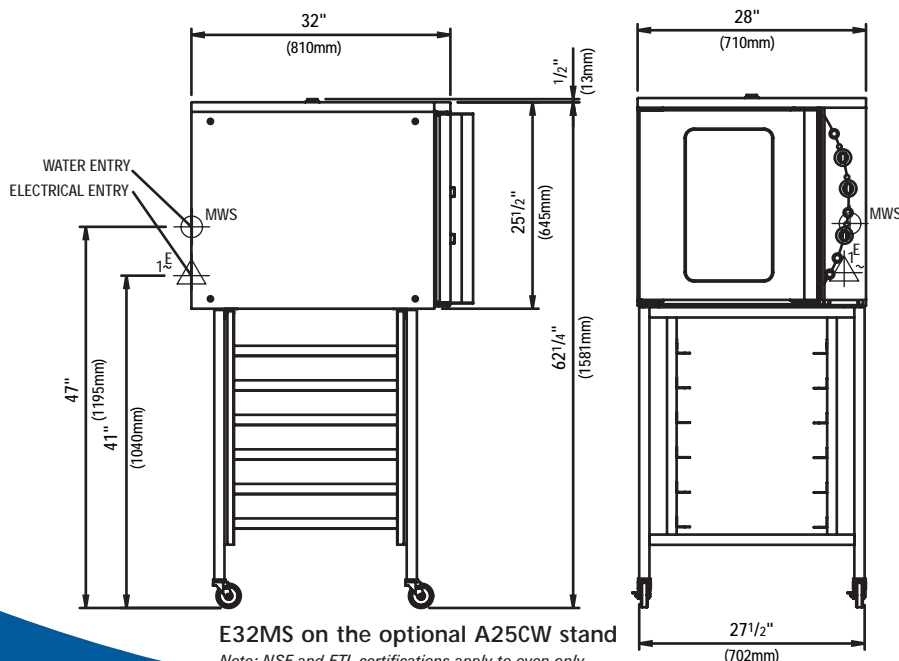

E32MS on the optional A25CW stand

Note: NSF and ETL certifications apply to oven only.

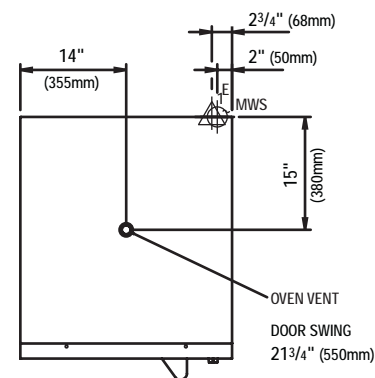

ISO 9001
All Turbofan products are designed and manufactured by Moffat Ltd using the internationally recognised ISO 9001 quality management system, covering design, manufacture and final inspection, ensuring consistent high quality at all times.



www.moffat.com

U.S.A

Moffat Inc
3765 Champion Boulevard
Winston-Salem
North Carolina 27105
Call Free 1800 551 8795
Ph 336-661 0257
Fax 336-661 9546
Email sales@moffat.com
www.moffat.com

Canada

Serve Canada
22 Ashwarren Road
Downview
Ontario, M3J 1Z5
Ph 416-631 0601
Fax 416-631 0315
Email info@servecanada.com

Australia

Moffat Pty Limited
740 Springvale Rd
Mulgrave
Victoria 3170
Australia
Ph 03-9518 3888
Fax 03-9518 3833
Email vsales@moffat.com.au
www.moffat.com.au

New Zealand

Moffat Limited
16 Osborne St
PO Box 10-001
Christchurch
New Zealand
Ph 03-389 1007
Fax 03-389 1276
Email sales@moffat.co.nz
www.moffat.co.nz

United Kingdom

Blue Seal Limited
Units 6-7 Mount St
Business Park
Birmingham B7 5QU
England
Ph 0121-327 5575
Fax 0121-327 9711
Email sales@blue-seal.co.uk
www.blue-seal.co.uk

