















MOFFAT® E89AMSW

Proofer and Holding Cabinet

-  Robust stainless steel exterior for long life
-  Stainless steel door with full viewing window for extra visibility
-  Door is field reversible for line end positioning
-  Heavy duty stainless steel door handle
-  8 full sheet pan capacity
-  Steam pan racking option
-  Auto water fill (hook-up optional)
-  Variable heat control
-  Variable humidity control
-  Stainless steel interior
-  Low velocity fan
-  Door condensate collection drawer
-  Casters as standard
-  110V plug in connection



E89AMSW



Order Toll Free 1800 551 8795

E89AMSW

Unit shall be a Moffat electrically heated proofer and holding cabinet E.T. L listed (UL Std 197) and NSF listed (NSF - 4). The proofer and holding cabinet shall have a stainless steel interior and stainless steel top and sides. Proofer cabinet shall be fully insulated with a single stainless steel door and full viewing window. Door shall be field reversible. Unit shall have capacity for up to 16 half size sheet pans or 8 full size sheet pans. A single speed fan shall gently and evenly circulate air around the proofer cabinet. Cabinet temperature shall be controlled by a thermostat and humidity via a humidity sensor and control. A thermometer shall indicate the cabinet temperature. A single element shall heat the cabinet with an additional element heating water in the water tank. Proofer and holding cabinet shall be mounted on casters, fixed at the rear brake and swivel at the front. Proofer and holding cabinet shall operate independently or in combination with Moffat's Turbofan model E32 or G32 convection ovens. Proofer and holding cabinet shall be fitted with a NEMA 5-15P cordset.

MOFFAT® E89AMSW

Proofer and Holding Cabinet

MOFFAT®

www.moffat.com

U.S.A

Moffat Inc
3765 Champion Boulevard
Winston-Salem
North Carolina 27105
Call Free 1800 551 8795
Ph 336-661 0257
Fax 336-661 9546
Email sales@moffat.com
www.moffat.com

Canada

Serve Canada
22 Ashwarren Road
Downview
Ontario, M3J 1Z5
Ph 416-631 0601
Fax 416-631 0315
Email info@servecanada.com

Australia

Moffat Pty Limited
740 Springvale Rd
Mulgrave
Victoria 3170
Australia
Ph 03-9518 3888
Fax 03-9518 3833
Email vsales@moffat.com.au
www.moffat.com.au

New Zealand

Moffat Limited
16 Osborne St
PO Box 10-001
Christchurch
New Zealand
Ph 03-389 1007
Fax 03-389 1276
Email sales@moffat.co.nz
www.moffat.co.nz

United Kingdom

Blue Seal Limited
Units 6-7 Mount St
Business Park
Birmingham B7 5QU
England
Ph 0121-327 5575
Fax 0121-327 9711
Email sales@blue-seal.co.uk
www.blue-seal.co.uk

CONSTRUCTION

8 pan capacity
Stainless steel front and sides
Field reversible full view door
Full stainless steel door handle
Stainless steel racking system
Accepts half or full size pans
Fully insulated
Stainless steel control panel with overlay
Door condensate collection drawer

CONTROLS

Off/Proof/Hold switch
Mechanical thermostat
Variable heat 32°F to 185°F
Variable humidity
Cabinet temperature thermometer

CLEANING AND SERVICING

Easy clean surfaces
Removable racking system
Removable water tank
Access to all controls from front panel
Full access side service panel
No tools required to replace lamps

OPTIONS

Steam pan racking kit
Double stacking kit

SPECIFICATIONS

Electrical requirements
110-120V, 50/60Hz, 1P+N+E, 1.5kW, 12.5A
NEMA 5-15P cordset fitted

Water

$\frac{3}{4}$ " thread
80psi max inlet pressure
20psi min inlet pressure

External Dimensions

Width 28" (710mm)
Height 35 $\frac{1}{2}$ " (900mm)
Depth 32" (810mm)

Internal Dimensions

Width 19" (480mm)
Height 26 $\frac{3}{4}$ " (680mm)
Depth 28" (715mm)

Nett Weight

187lbs (85kg)

Packing Data

309lbs (140kg)
26.5ft³ (0.75m³)
Width 29 $\frac{1}{2}$ " (750mm)
Height 40 $\frac{1}{2}$ " (1030mm)
Depth 37" (945mm)

Clearances

Left side -
Right side 1" (25mm)
Rear -
Top -

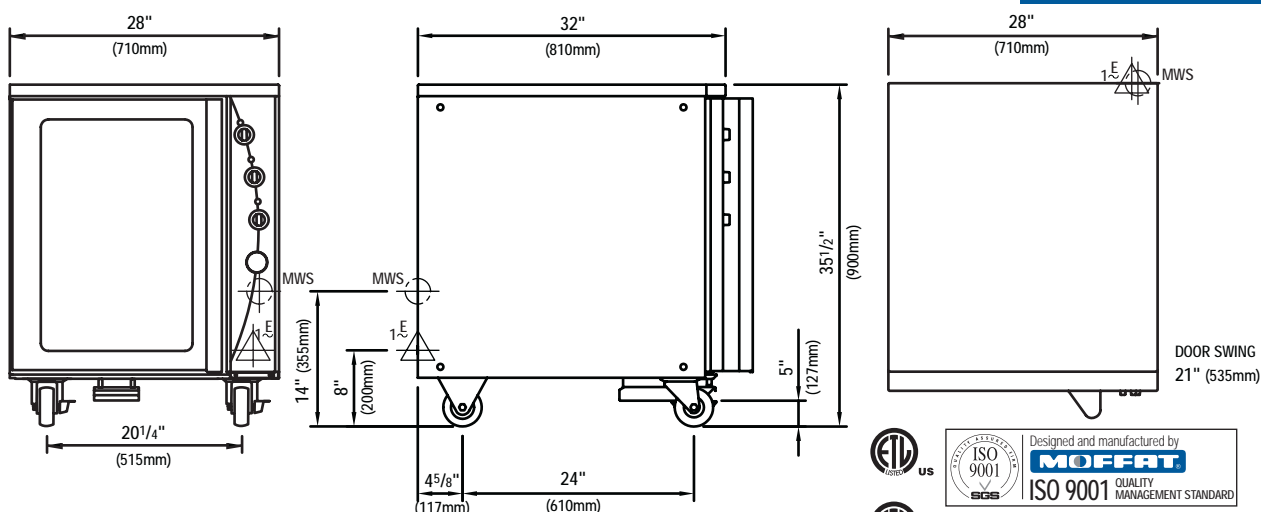

ISO 9001

All Turbofan products are designed and manufactured by Moffat Ltd using the internationally recognised ISO 9001 quality management system, covering design, manufacture and final inspection, ensuring consistent high quality at all times.

